

TELEPHONE HYBRID-2

USER MANUAL

Version 1.001

Dear Customer,

Thank you for choosing the Telephone Hybrid-2.

This time you are not faced with a huge manual because it is simply not necessary because of the natural recognition of all functions on the user interface. All functions are self-explanatory and you will certainly appreciate the ergonomics of this design.

We are confident that you will be using the Telephone Hybrid for many years to come, and wish you a lot of success with your operation.

With kind regards,



**D & R Electronica Weesp b.v.
Rijkade 15b - 1382 GS Weesp
Tel.: 0294 - 418014
Fax: 0294 - 416987**

**Duco de Rijk
PRESIDENT**

D&R ELECTRONICA WEESP B.V.
Rijnkade 15B
1382 GS WEESP-HOLLAND
The Netherlands
Phone: 0294-418 014
Fax: 0294-416 987
Website: <http://www.d-r.nl>
E-mail: info@d-r.nl

D&R's newest Telephone Hybrid-2 is the active version of the well known passive one, successfully sold over the last 5 years.

Its concept originates from many demands for a more sophisticated hybrid with more features. The Telephone Hybrid-2 is an analogue unit with digital control and features like ducking making intelligibility a lot better in broadcast..



What is a telephone hybrid?

Telephone hybrids provide the interface between professional audio equipment and the public telephone network. They provide protection for your equipment and the public telephone lines, allowing for varying line signals and line conditions. Automatically canceling out the unwanted signal they also facilitate two-way communication down a single telephone line.

Each hybrid has a telephone line connection, a handset connection and separate connectors for audio input and output from a broadcast mixer, or other professional audio source.

A large proportion of D&R hybrids are used in radio and television broadcasting applications allowing external callers to be connected to the studio mixing console. Most of the other units are supplied to communication operations allowing extremely effective conversion between 4-wire audio circuits and standard telephone lines.

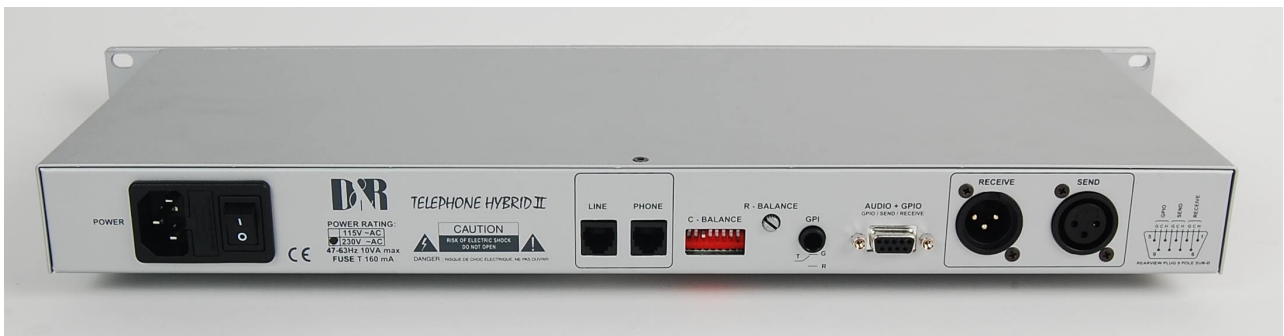

Front panel lay-out



CONNECT BUTTON: (RING)	Line connect switch to connect and disconnect calls from the telephone line. It can be remotely driven by connecting a switch to the GPIO sub D connector.
LC:	Variable Low Cut filter to filter out unwanted low frequency noise.
HC:	Variable High Cut filter to filter out unwanted high frequency noise.
Ducking	Indicates when caller's signal is reduced.
RECEIVE:	Level control for incoming signal from caller.
SEND:	Level control for outgoing signal to caller.

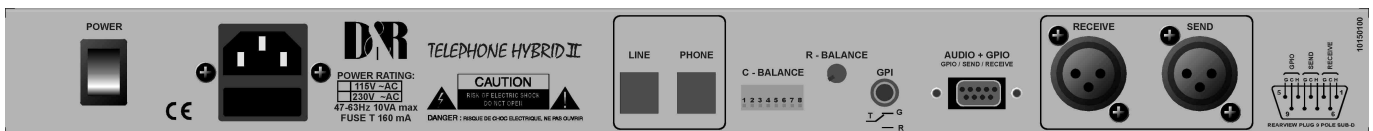

Back panel lay-out

Power	mains power switch.
Power Cord	The unit is powered by a removable IEC type power cord. An internal switch is provided for 115/230V selection.
LINE:	RJ-12 connector to connect with the public telephone network.
PHONE:	RJ-12 connector to connect with a handset.
C-BALANCE:	8 pole mini-dip switch to select the optimum side tone attenuation.
R-BALANCE	Internal potentiometer to adjust for optimum side tone attenuation.
GPI	Jack connector for remote control. (1:1 for D&R's Scorpius console)
AUDIO + GPIO	A combination of audio in/outputs and logic for D&R's Lyra console.
RECEIVE	Male XLR to be connected to input of the mixer.
SEND	Female XLR input to be connected to Mix Minus/Clean feed (N-1) output of the mixer.

SYSTEM DESCRIPTION.

A large ring button enables you to pick up the line from the unit itself or from your mixer when connected via its GPIO to the telephone Hybrid. When a call comes in it lights up green in the rhythm of the ring. When the line is picked up by pushing the button it turns into red. When it starts blinking red the line connection is lost.

Both levels of receive and send can be adjusted to suit your requirements. Incoming signals can be tailored by the variable high and low cut signal while talking to people calling the station.

A ducking system reduces the incoming signal while talking to people calling the station to provide for an improved intelligibility.

HIGH LIGHTS.

- Active balanced interfacing.
- Variable high and low cut filters.
- Industry standard connectors
- Superb audio separation.
- Externally adjustable R and C balance.
- Remotely controllable.
- GPIO interfacing with mixing consoles.
- Auto Ducking.

+SETTING UP PROCEDURE



Connect the two wires of the telephone line's wall unit to the RJ-11 connector labeled LINE and connect the telephone appliance itself to the Hybrid's RJ-11 connector labeled PHONE. Note that to originate calls, a local phone must be connected to the system.

Now the hybrid is interfaced (fully balanced) between your telephone appliance and its connection to the outside world. The hybrid can now split the send and return signals.

Now connect the hybrid's balanced audio input (SEND on XLR male) to a (preferable) balanced mixer output of around +4dBu. This output has to be the mix of all signals except the signal coming from the hybrid itself to avoid feedback. An Aux. output will do or in broadcast mixers a clean-feed is the best.

The balanced RECEIVE output of the Hybrid has to be connected to a line input of the mixing console.

Note that this signal is NOT to be send to the output where the Hybrid's input is connected to. So in case of use of an Aux send this local channel Aux send needs to be turned off. In case of use of a clean-feed buss, this input channel needs to be disconnected from the clean-feed buss.

Turn the LC control fully counter clockwise and the HC control fully clockwise.

Position RECEIVE and SEND controls in their mid position.

If a local phone is connected, originate a call to a remote side. If no local phone is present, someone at a remote site must call you. When a call comes in the large ring BUTTON on the left side of the unit lights up green in the rhythm of the ring. When the line is picked up by pushing the button it turns into red. When it starts blinking red the line connection is lost.

If you are at the originating side pres the CONNECT button to connect the Telephone Hybrid-2 to the phone line after the call has been established. The phone will be disconnected now. The caller will now hear the signal send to the Hybrid and the output of the Hybrid will present the callers signal only with the send signal heavily attenuated.

To achieve the optimum attenuation you need to adjust the C and R balance first.

This is how it is performed:

1. Check if the telephone connection is established and all connections to the mixing console are correctly wired.
2. Now activate a CUE/PFL/SOLO button of the mixing console channel where the return signal of the Hybrid is connected to. You will faintly hear the send signal coming out of the mixing console.
3. Adjust the R-Balance for minimum feed through of the mixers send signal.
4. Listen now which mini-dip switch gives a further reduction of the return signal.
5. Maybe it is good to re-adjust the R-balance after having selected another dip-switch.
6. Repeat steps 3 and 4 until no further improvement are achieved.

DUCKING

The Hybrid has an automatic gain adjustment of the incoming signal from the caller when the presenter speaks. This feature both improves the side tone reduction and gives the presenter a level advantage over the caller when he interrupts the caller. When both parties are speaking the caller's signal is reduced then.

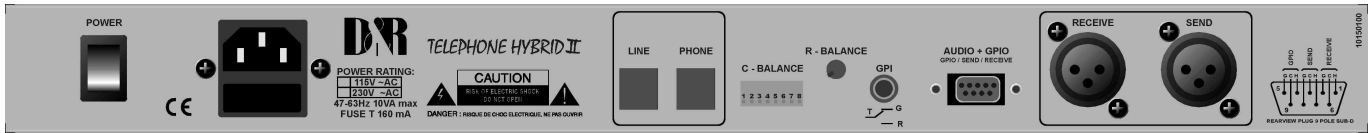

INPUTS / OUTPUTS

SEND (to caller)

XLR FEMALE	TYPE	CONNECTION
Pin 1	Screen	Audio ground
Pin 2	Phase	Audio + (input)
Pin 3	Non-phase	Audio – (input)

RECEIVE (from caller)

XLR MALE	TYPE	CONNECTION
Pin 1	Screen	Audio ground
Pin 2	Phase	Audio + (output)
Pin 3	Non-phase	Audio – (output)

SUB D-9 AUDIO + GPIO

GPIO / SEND / RECEIVE	FUNCTION	CONNECTION
Pin 1	Receive (from caller)	Audio + (output)
Pin 6	Receive (from caller)	Audio - (output)
Pin 2	Receive (from caller)	Audio ground
Pin 7	Send (to caller)	Audio + (input)
Pin 3	Send (to caller)	Audio – (input)
Pin 8	Send (to caller)	Audio ground
Pin 4	Logic ground	47 Ohm to ground
Pin 9	GPI	+ 5volt TTL input
Pin 5	GPO	Open collector to ground

GPI

GPI	FUNCTION	CONNECTION
Tip	Pull down	47 ohm to ground
Ring	Pull up	+5 volt via 10kohm
Sleeve	No	Not connected

PHONE

PHONE RJ12	FUNCTION	CONNECTION
Pin 1	n.c.	
Pin 2	A (telephone line)	In/out
Pin 3	B (telephone line)	In/out
Pin 4	n.c.	

LINE

LINE RJ12	FUNCTION	CONNECTION
Pin 1	n.c.	
Pin 2	A (telephone line)	In/out
Pin 3	B (telephone line)	In/out
Pin 4	n.c.	

SPECIFICATIONS

Audio Inputs

SEND	
Impedance	10k Ohm, electronically balanced
Common mode rejection	>40dB
Maximum input level	+26dBu
Nominal input level	+4 dBu
Frequency response	20Hz – 15kHz (-3dB variable via HC and LC filters)
Connectors	XLR type 3 pin female
Gain range receive control	40dB

RECEIVE	
Impedance	< 50 Ohm, electronically balanced
Common mode rejection	>40dB
Maximum output level	+26dBu
Nominal output level	+4 dBu
Bandwidth to telephone line	250Hz – 4kHz, -3dB ref 1 kHz
Telephone line impedance	Nominally 600 ohm
Telephone line impedance range	300 ohm to 1500 ohm
Connectors	XLR type 3 pin male
Gain range send control	+6dB to –20dB
GENERAL	
Distortion	Less than 0.1% (0dBu out)
Power supply	115v / 230 v AC / 50/60Hz (factory set, NOT do this yourself)
Power consumption	10VA Maximum
Dimensions	1 HE front panel: 482x44mm
	Frame: 430x41x175mm (width x height x depth)
Weight	2.2 kg net excl packing

INSTALLATION

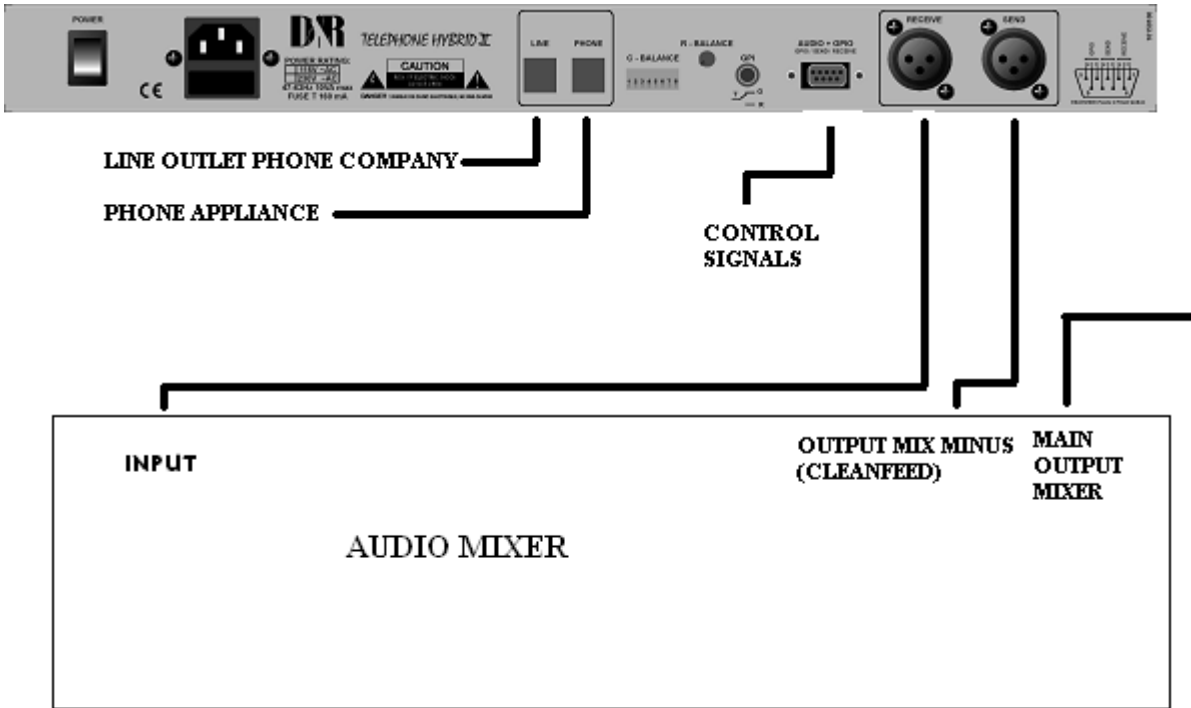

DECLARATION OF CONFORMITY

Manufacturers Name: D&R Electronica Weesp b.v.

Manufacturers Address: Rijkade 15
1382 GS Weesp,
The Netherlands

declares that the product

TELEPHONE HYBRID-2

Which refers to this declaration, is in accordance with the following standards or standardized documents:

EN 50081-1	EN 55013 A 12
EN 50082-1	EN 55022
EN 60065	EN 61000-3-2
EN 55020	EN 61000-3-3

Supplementary Information:

The products herewith complies with the requirements of the EMC Directive 89/336/EWG and 73/23/EWG as amended by the CE Marking Directive 93/68/EEC (1993).



D & R Electronica Weesp b.v.
Rijkade 15b - 1382 GS Weesp
Tel.: 0294 - 418014
Fax: 0294 - 416987

Duco de Rijk
president

August 2003

D&R Electronica Weesp b.v.
Rijkade 15 B
1382 GS WEESP
The Netherlands

PRODUCT SAFETY

This product is manufactured with the highest standards and is double checked in our quality control department for reliability in the "HIGH VOLTAGE" section.

CAUTION

Never remove any panels, or open this equipment. No user serviceable parts inside.

Equipment power supply must be grounded at all times.

Only use this product as described, in user manual or brochure.

Do not operate this equipment in high humidity or expose it to water or other liquids.

Check the AC power supply cable to assure secure contact.

Have your equipment checked yearly by a qualified dealer service center.

Hazardous electrical shock can be avoided by carefully following the above rules.

PLEASE READ THE FOLLOWING INFORMATION

Especially in sound equipment on stage the following information is essential to know.

An electrical shock is caused by voltage and current, actually it is the current that causes the shock.

In practice the higher the voltage the higher the current will be and the higher the shock.

But there is another thing to consider and it is resistance.

When the resistance in Ohms is high between two poles, the current will be low and vice versa.

All three of these; voltage, current, and resistance are important in determining the effect of an electrical shock.

However, the severity of a shock primarily determined by the amount of current flowing through a person.

A person can feel a shock because the muscles in a body respond to electrical current and because the heart is a muscle it can affect, when the current is high enough.

Current can also be fatal when it causes the chest muscles to contract and stop breathing. At what potential is current dangerous.

Well the first feeling of current is a tingle at 0.001 Amp of current.

The current between 0.1 Amp and 0.2 Amp is fatal.

Imagine that your home fuses of 20 Amp can handle 200 times more current than is necessary to kill. How does resistance affect the shock a person feels.

A typical resistance between one hand to the other in "dry" condition could well over 100,000 Ohm.

If you are playing on stage your body is perspiring extensively and your body resistance is lowered by more than 50%. This is a situation in which current can easily flow.

Current will flow when there is a difference in ground potential between equipment on stage and in the P.A. system. Please do check if there is any potential between the housing of the mikes and the guitar synth amps, which will be linked by your body on stage. Imagine, a guitar in your hand and your lips close to the mike! A ground potential difference of above 10 volts is not unusual, in improperly wired buildings it can possibly be as high as 240 volts. Although

removing the ground wire sometimes cures a system hum, it will create a very hazardous situation for the performing musician.

Always earth all your equipment by the grounding pin in your mains plug.

Hum loops should be only cured by proper wiring and isolation input/output transformers.

Replace fuses always with the same type and rating after the equipment has been turned off and unplugged.

If the fuse blows again you have an equipment failure, do not use it again and return it to your dealer for repair.

And last but not least be careful not to touch a person being shocked as you, yourself could also be shocked.

Once removed from the shock, have someone send for medical help immediately

Always keep the above mentioned information in mind when using electrically powered equipment.

Technische Hinweise zum Anschluss des Telefonhybrids

Anschlussbelegung RJ11 / Keine Funktion des Telefons:

Manchmal kommt es vor, dass ein Telefon nicht am Telefonhybrid funktioniert. Dies liegt nicht an einem Gerätedefekt, sondern an unterschiedlichen Anschlussbelegungen der Telefonleitungen (RJ11) am Telefon. Nachfolgenden führen wir die richtige Belegung der einzelnen Stecker auf, damit der Telefonhybrid betrieben werden kann:

TAE-Stecker (Wandanschluss):

F-Codierung: Abk. für "Fernsprecher-Codierung". Durch Nasen am Stecker passen die Stecker von Telefonen immer nur in F-Buchsen Anschlussdose.

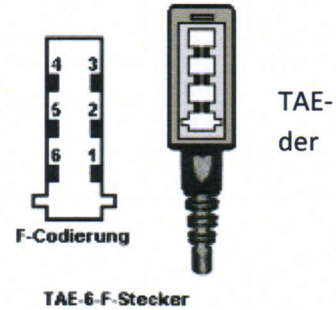

F-Codierung				
	1	La oder a1	a-Leitungsader	weiß
	2	Lb oder b1	b-Leitungsader	braun
	3	W	Externer Wecker/Klingel	grün
	4	E	Erde für Nebenstelle	gelb
	5	b2	b-Leitungsader vom Gerät zurück	-
	6	a2	a-Leitungsader vom Gerät zurück	-



Für den Betrieb des Telefons und des Telefonhybrids ist die Belegung 1 und 2 erforderlich.

RJ11-Stecker (Western-Stecker): Belegung Telefonhybrid (PHONE + LINE)

6 Kontakte (davon 4 belegt), Westernstecker 6P4C. Die beiden äußeren Kontakte fehlen.

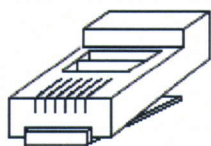

- 1 = frei
- 2 = frei
- 3 = La oder a1 a-Leitungsader
- 4 = Lb oder b1 b-Leitungsader
- 5 = frei
- 6 = frei

Technische Hinweise zum Anschluss des Telefonhybrids

RJ11-Stecker (Western-Stecker): Belegung Telefon Internationale Norm

6 Kontakte (davon 4 belegt), Westernstecker 6P4C. Die beiden äußeren Kontakte fehlen.

Telefone mit dieser Beschaltung funktionieren mit jedem Standard – Kabel am Telefonhybrid

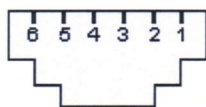
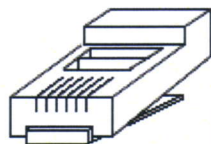

- 1 = frei
- 2 = frei
- 3 = La oder a1 a-Leitungsader
- 4 = Lb oder b1 b-Leitungsader
- 5 = frei
- 6 = frei

RJ11-Stecker (Western-Stecker): Belegung Telefon (z.T. Telekom / Siemens)

6 Kontakte (davon 4 belegt), Westernstecker 6P4C. Die beiden äußeren Kontakte fehlen.

Für den Betrieb bestimmter Telefone muss ein angepasstes Kabel verwendet werden, sonst ist kein Betrieb des Telefons möglich.

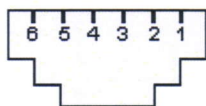
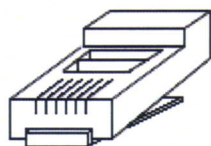

- 1 = frei
- 2 = Lb oder b1 b-Leitungsader
- 3 = frei
- 4 = frei
- 5 = La oder a1 a-Leitungsader
- 6 = frei

Der Hersteller hat meistens folgendes Kabel im Lieferumfang:

TAE-F

RJ11

- 1 La oder a1 a-Leitungsader ---> 5 = La oder a1 a-Leitungsader
- 2 Lb oder b1 b-Leitungsader ---> 2 = Lb oder b1 b-Leitungsader

Wenn dieses Kabel in den Hybrid gesteckt wird, ist keine Funktion möglich, da das Gerät auf 3 und 4 funktioniert und nicht auf 5 und 2 !!!

Technische Hinweise zum Anschluss des Telefonhybrids

Hier der Belegungsplan als Gesamtübersicht

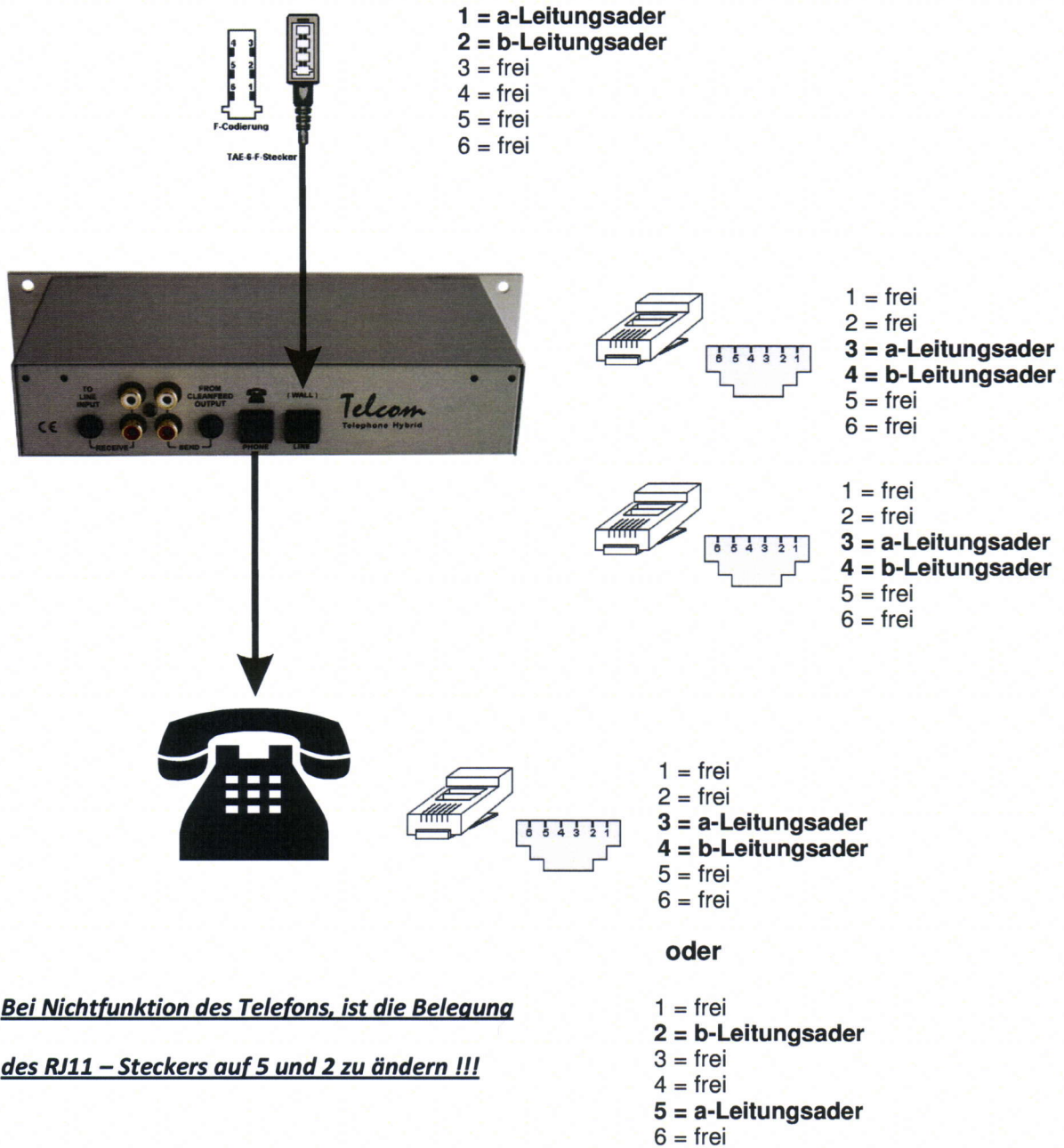

TELEPHONE HYBRID-2

SERVICE MANUAL

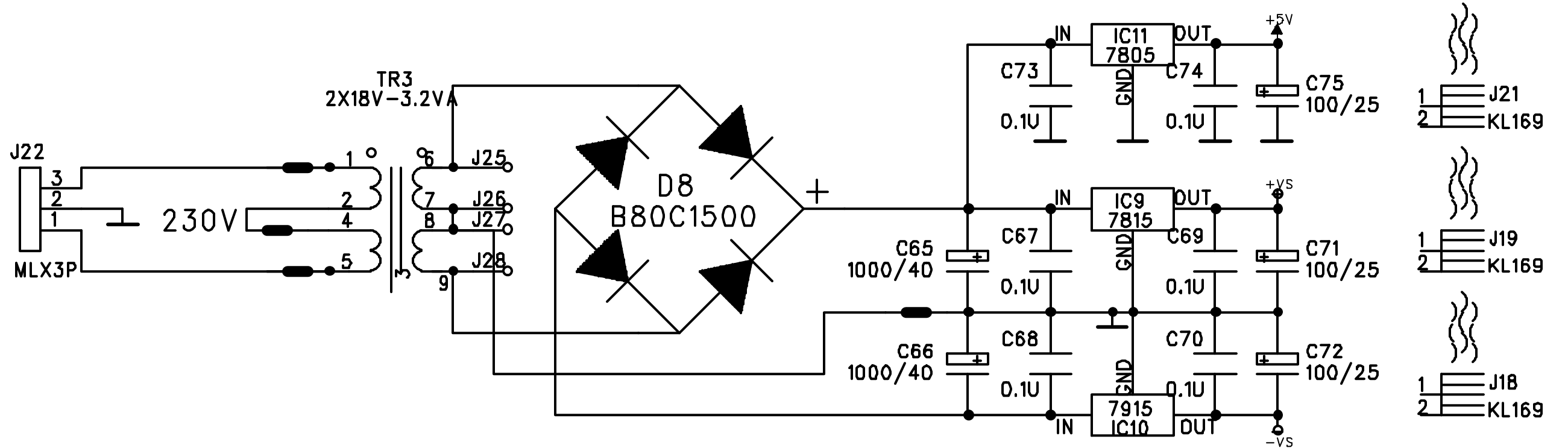

J29
J30
J31

J16 J23
J17 J24

LOGO
DR1



Rijkade 15b
1382 GS Weesp
The Netherlands
phone: 0294-418014
fax: 0294-416987

D&R Electronica B.V.

Design: Jan Betten

Modify: _____

Project: **Hybrid II**

Title: **Hybrid**

File: **hybrid2_a.sch**

code: **20851510**

Date: **25-4-2003**

Sheet: **2 of 2**

Rev:

A

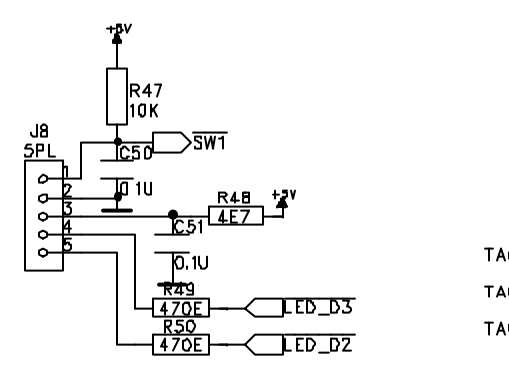
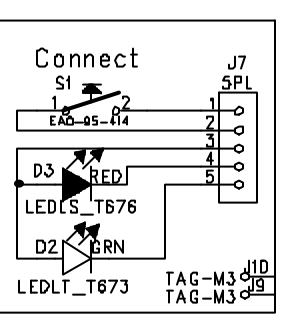
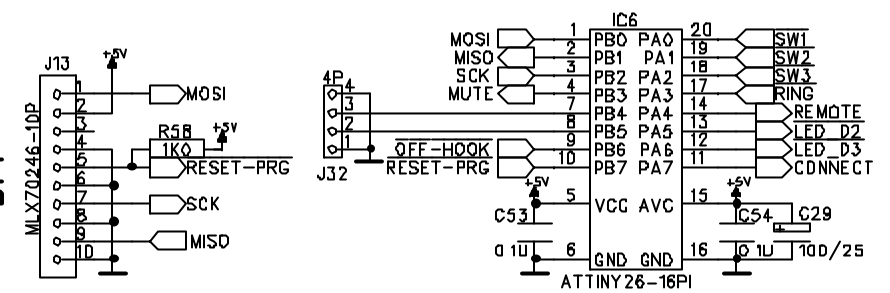
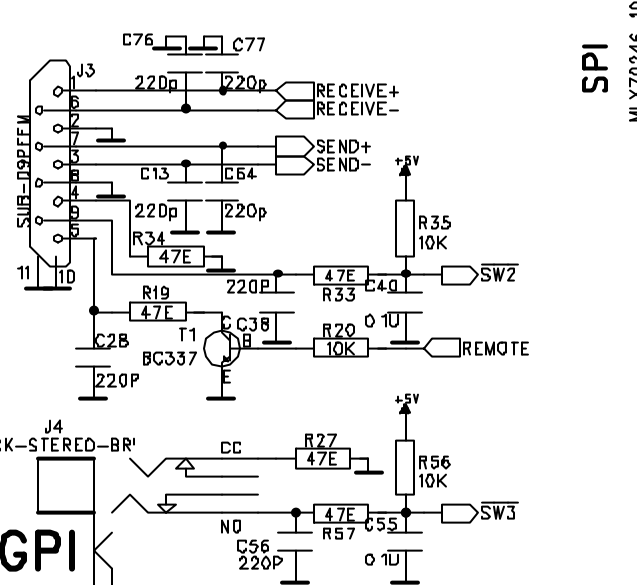
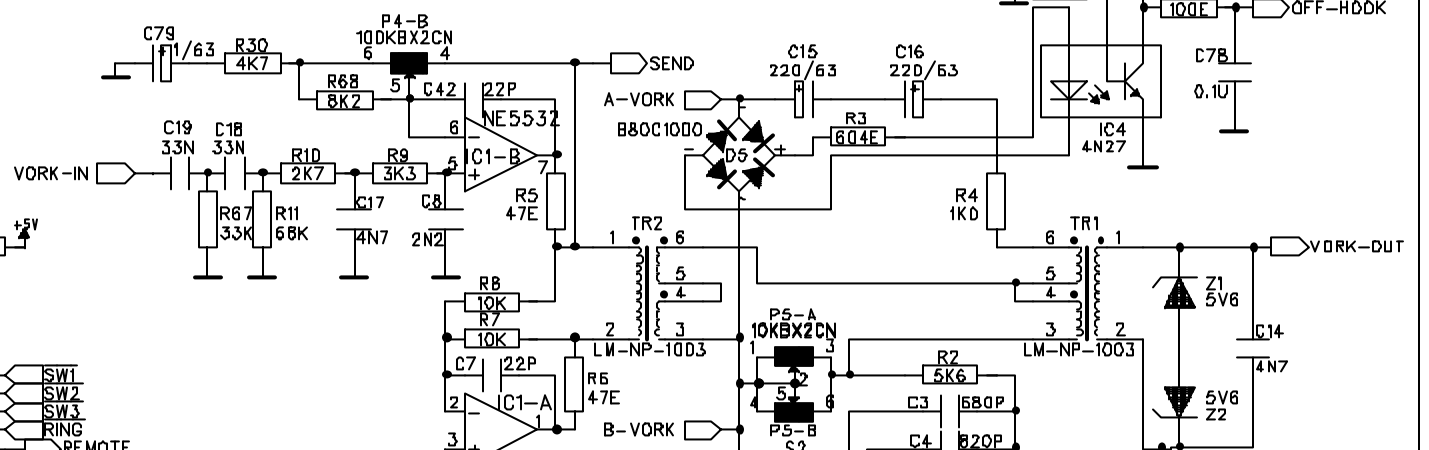
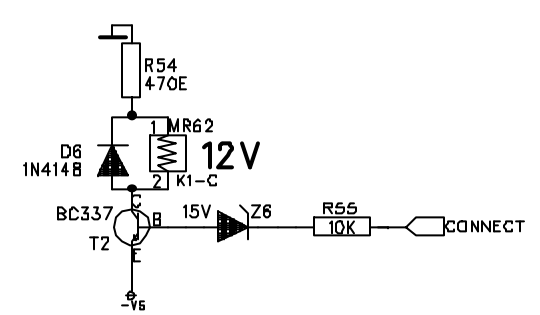
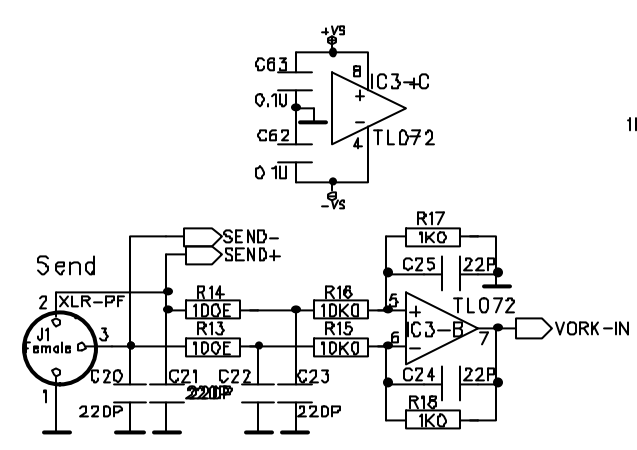
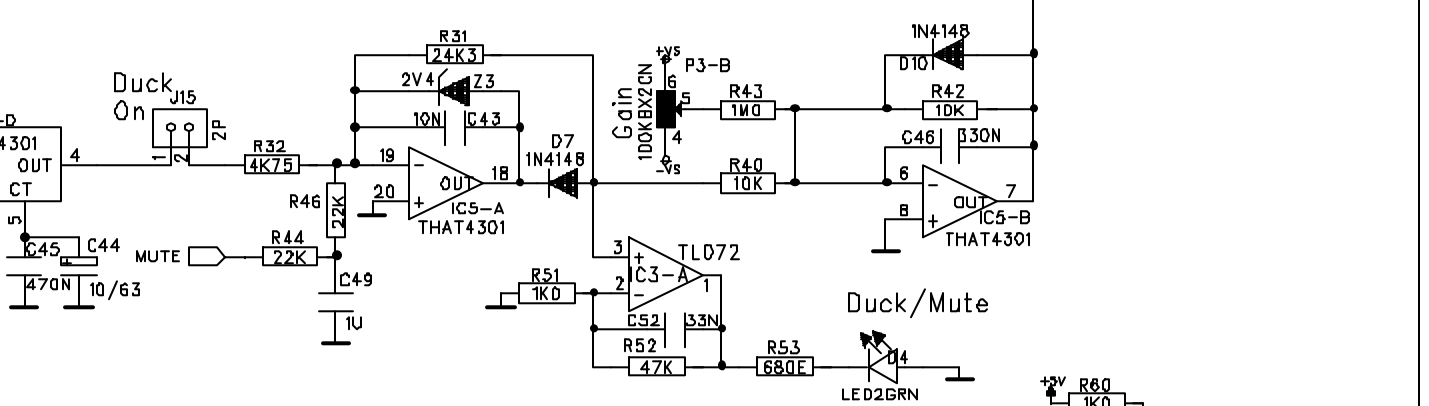
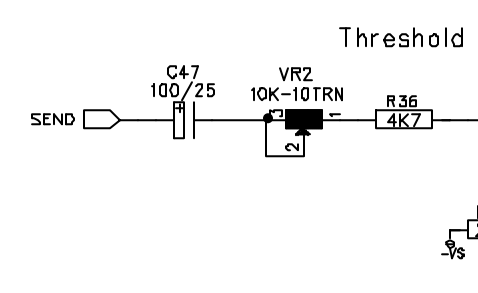
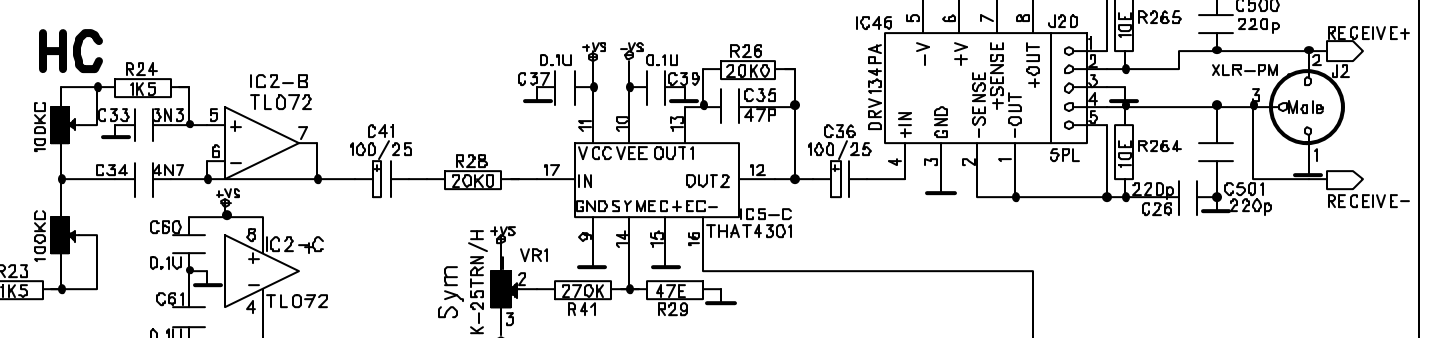
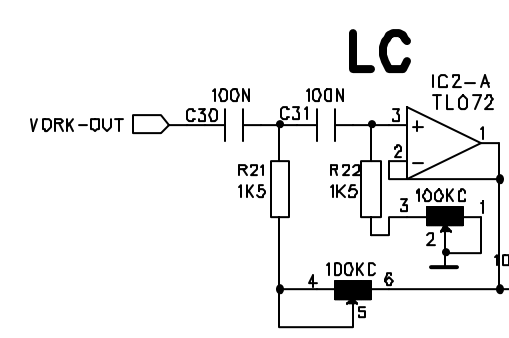
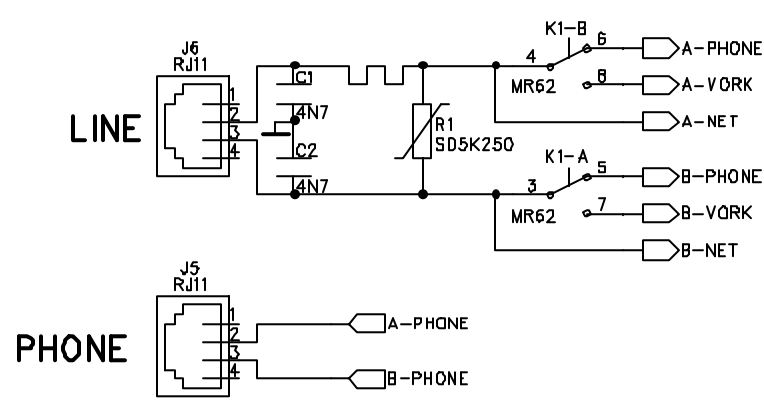
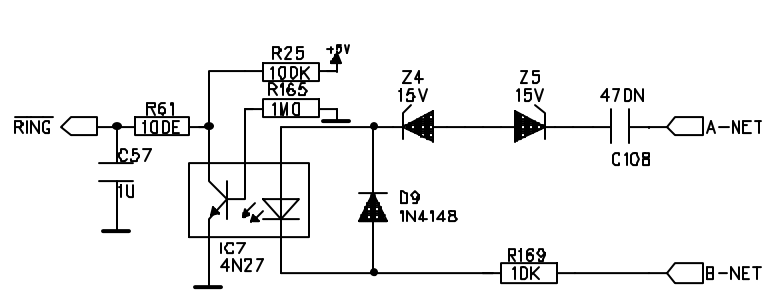

	Rijnkade 15b 1382 GS Weesp The Netherlands phone: 0294-418014 fax: 0294-416987		Project: Hybrid II
	D&R Electronica B.V.		Title: Hybrid
TAG-M3 ϕ 14 TAG-M3 ϕ 12 TAG-M3 ϕ 11	Design: Jan Betten	File: hybrid2_a.sch	code: 20851510
Modify:	Date: 25-4-2003	Sheet: 1 of 1	Rev: A

Datum : 14-08-03 [16:25]
 D&R Electronica Weesp B.V.

PROD.STUKL.PRINTEN GES. OP OMS

Blad : 1
 Bedrijf : 100

Positie	Artikel code	Omschrijving	Leveranciercode	Netto hoeveelheid	Vrd eh.	Verval datum
Maakartikel :		60898510 Telephone Hybride II 19"		Stuklijsteenheden:		1 st
280	10700659	Afstandshdr mt zeskant+tap15mm		4.0000	st	
220	10600007	Cablesocket + hole M3 red		1.0000	st	
180	10600008	Cablesocket flat6.3x0.8mm Blue		1.0000	st	
160	10600155	Conn assembly 5P (Teleporter)		1.0000	st	
260	10600458	Conn housing 3p 3.96mm		1.0000	st	
270	10600471	Crimp contact 406 series tin		3.0000	st	
40	10800981	Doos Telephonehybrid II		1.0000	st	
20	10150100	Frame TELEPHONE-HYBRID-2 19"		1.0000	st	
30	10100047	Front TELEPHONE-HYBRID-2/P		1.0000	st	
150	10500084	Insul. plate 9.5" randapp. PVC		1.0000	st	
130	10700625	Kartelring M3 (buitenvertand)		2.0000	st	
170	10450090	Knob SiF Rub/Gry TPN110 006/13		4.0000	st	
50	10600701	Mains inlet SKT MS3 + FR MS3		1.0000	st	
60	10600498	Mains lead 3 core Euroconnecto		1.0000	st	
70	10700610	Moer M3		4.0000	st	
200	10650383	Montagesnoer 1.5mm ² (blauw)		35.0000	cm	
190	10650391	Montagesnoer 1.5mm ² (bruin)		35.0000	cm	
210	10650388	Montagesnoer 1.5mm ² (groen)		30.0000	cm	
10	20851510	PCB ins Telephone Hybrid II		1.0000	st	
140	10700600	Parker 2.9x6.5 verz zwart		4.0000	st	
80	10700656	Plakvoet SJ-5012		4.0000	st	
90	10800956	Schuimblok 9.5"		2.0000	st	
290	10800982	Schuimplaat 530x280x20 mm HLTR		2.0000	st	
240	10500683	Shrinksleeve 3.2>1.6 black		5.0000	cm	
250	10500684	Shrinksleeve 38.1>19.0 black		5.0000	cm	
230	10500682	Shrinksleeve 6.4>3.2 black		10.0000	cm	
100	10550020	Switch mains small blk no lmp		1.0000	st	
120	10700787	Taptite M3x6 bolkopozidr/zwrt		5.0000	st	
110	10700790	Taptite M3x6 verzkop/pozidr/zw		4.0000	st	

Datum : 14-08-03 [16:41]
 D&R Electronica Weesp B.V.

PROD.STUKL.PRINTEN GES. OP OMS

Blad : 1
 Bedrijf : 100

Positie	Artikel code	Omschrijving	Leveranciercode	Netto hoeveelheid	Vrd eh.	Verval- datum
Maakartikel :		20851510 PCB ins Telephone Hybrid II		Stuklijsteenheid:		1 st
480	10401246	Capacitor 1n0 R5.0 poly		1.0000	st	
490	10401248	Capacitor 2n2 R5.0 poly		2.0000	st	
500	10401249	Capacitor 3n3 R5.0 poly		1.0000	st	
510	10401250	Capacitor 4n7 R5.0 poly		6.0000	st	
520	10401251	Capacitor 6n8 R5.0 poly		1.0000	st	
530	10400278	Capacitor 8n2 R5.0 poly		1.0000	st	
540	10401253	Capacitor 10n R5.0 poly		1.0000	st	
550	10400273	Capacitor 12n R5.0 poly		1.0000	st	
430	10400217	Capacitor 22p R2.5 ker		4.0000	st	
560	10401257	Capacitor 33n R5.0 poly		4.0000	st	
440	10400221	Capacitor 47p R2.5 ker		1.0000	st	
610	10401241	Capacitor 100n/50V R5.0 ker		23.0000	st	
450	10400229	Capacitor 220p R2.5 ker		15.0000	st	
590	10400270	Capacitor 470n R5.0 poly		2.0000	st	
460	10400234	Capacitor 680p R2.5 ker		1.0000	st	
470	10400235	Capacitor 820p R2.5 ker		1.0000	st	
570	10401261	Capacitor 100n R5.0 poly		2.0000	st	
600	10401268	Capacitor 1uF R5.0 poly		2.0000	st	
580	10401265	Capacitor 330n R5.0 poly		1.0000	st	
920	10600445	Conn chass 805-D 4p (RJ11)		2.0000	st	
840	10600043	Conn sub-D9 female pcb		1.0000	st	
20	10250342	Diode 1N4148 (signal)		3.0000	st	
760	10400292	Elco 100uF/ 25V rad R5.0		8.0000	st	
770	10400293	Elco 220uF/ 63V radial R5.0		2.0000	st	
780	10400297	Elco 1000uF/40V axial(30x12,5)		2.0000	st	
750	10400284	Elco 10uF/50V radial R5.0		1.0000	st	
790	10600505	Header 2p pin 0° sngl		1.0000	st	
830	10600474	Header 3p 0° 3.96		1.0000	st	
910	10600513	Header 5P Lock 0° 2.54		2.0000	st	
800	10600514	Header 5P Lock 90° 2.54		1.0000	st	
950	10600506	Header 10P box 0° 2.54		1.0000	st	
640	10250014	IC 4N27 (optp-coupler)		2.0000	st	
650	10250291	IC 7805 TO220 SGS (volt.reg)		1.0000	st	
660	10250320	IC 7815 TO220 Toshiba volt.reg		1.0000	st	
670	10250321	IC 7915 TO220 ONS (volt.reg)		1.0000	st	
960	10250457	IC ATTINY26-16PI DIL20		1.0000	st	
680	10250179	IC DRV-134PA (SSM2142)		1.0000	st	
690	10250307	IC NE5532 AP TI (dual-opamp)		1.0000	st	
700	10250043	IC THAT 4301 (VCA,RMS,3xopamp)		1.0000	st	
710	10250304	IC TL072 CP TI DIL-8		2.0000	st	
720	10600394	IC-socket 8 pins		3.0000	st	
970	10600398	IC-socket 20 pins:fork-contact		2.0000	st	
810	10600530	Jack Break slimline S253-84		1.0000	st	
80	10250384	Led 2mm green SLV-020210-020		2.0000	st	
110	10250421	Led SMD LS T673 R2T1-35 green		1.0000	st	
100	10250420	Led SMD LS T676-Q1R2-1 red		1.0000	st	
10	10201510	PCB Telephone Hybrid II-A		1.0000	st	
890	10300418	PotRK 100kCx4-50kB		2.0000	st	
880	10300421	RK09 100KBx2cc Short version		2.0000	st	
870	10300420	RK09 10KBx2cc Short version		1.0000	st	
70	10250346	Rect. B80C1500 (rectang)		1.0000	st	
60	10250345	Rect. B80C1500 (round)		1.0000	st	
900	10550010	Relay MT212VC93402 12V (2x om)		1.0000	st	

Datum : 14-08-03 [16:41]
 D&R Electronica Weesp B.V.

PROD.STUKL.PRINTEN GES. OP OMS

Blad : 2
 Bedrijf : 100

Positie	Artikel code	Omschrijving	Leveranciercode	Netto hoeveelheid	Vrd eh.	Verval datum
Maakartikel:		20851510 PCB ins Telephone Hybrid II		Stuklijsteenheden:	1	st
410	10350765	Resistor 1M0 5% 1/4W		3.0000	st	
200	10350729	Resistor 1k0 5% 1/4W		6.0000	st	
210	10350731	Resistor 1k5 5% 1/4W		4.0000	st	
420	10350768	Resistor 2M2 5% 1/4W		1.0000	st	
220	10350734	Resistor 2k7 5% 1/4W		1.0000	st	
230	10350735	Resistor 3k3 5% 1/4W		1.0000	st	
240	10350840	Resistor 3k92 1% 1/4W		1.0000	st	
120	10350704	Resistor 4E7 5% 1/4W		1.0000	st	
250	10350737	Resistor 4k7 5% 1/4W		1.0000	st	
260	10350844	Resistor 4k75 1% 1/4W		1.0000	st	
270	10350738	Resistor 5k6 5% 1/4W		1.0000	st	
280	10350520	Resistor 8k25 1% 1/4W		1.0000	st	
130	10350705	Resistor 10E 5% 1/4W		3.0000	st	
290	10350741	Resistor 10K 5% 1/4W		5.0000	st	
300	10350848	Resistor 10k0 1% 1/4W		2.0000	st	
330	10350856	Resistor 20k0 1% 1/4W		2.0000	st	
340	10350745	Resistor 22k 5% 1/4W		2.0000	st	
350	10350859	Resistor 24k3 1% 1/4W		1.0000	st	
360	10350861	Resistor 28k7 1% 1/4W		1.0000	st	
140	10350713	Resistor 47E 5% 1/4W		8.0000	st	
370	10350749	Resistor 47K 5% 1/4W		1.0000	st	
380	10350751	Resistor 68k 5% 1/4W		1.0000	st	
150	10350717	Resistor 100E 5% 1/4W		4.0000	st	
390	10350758	Resistor 270k 5% 1/4W		1.0000	st	
400	10350760	Resistor 390k 5% 1/4W		1.0000	st	
160	10350725	Resistor 470E 5% 1/4W		2.0000	st	
170	10350726	Resistor 560E 5% 1/4W		1.0000	st	
180	10350792	Resistor 604E 1% 1/4W		1.0000	st	
190	10350727	Resistor 680E 5% 1/4W		1.0000	st	
990	10350002	Resistor vdr SIOV-S05K250		1.0000	st	
930	10550215	Switch 95-414.7 Lrg Scorpius		1.0000	st	
980	10550460	Switch PIANO-DIP 76-serie 8p		1.0000	st	
940	10950018	Trafo LM-NP-1003-B (PT line)		2.0000	st	
740	10950582	Transf.PCB 3VA/2x18v/2x115v		1.0000	st	
730	10250332	Transistor BC337/25-RR Tape!!!		2.0000	st	
630	10300203	Trimmer 100k H 25turn (T93YB)		1.0000	st	
620	10300151	Trimmer 10K 1turn PT10LC		1.0000	st	
850	10600238	XLR chas 3p fem X907-02		1.0000	st	
860	10600798	XLR chass mal pl X906-02		1.0000	st	
50	10250359	Zenerdiode 15V0/400mW		2.0000	st	
30	10250340	Zenerdiode 2V4 / 400mW		1.0000	st	
40	10250351	Zenerdiode 5V6/400mW		2.0000	st	