

JEM K1 HAZER™ user manual



Safety information	3
Product overview	6
Product description.....	6
Features at a glance.....	6
Product details.....	7
Quick Start	8
Setting up	8
Making haze.....	8
Shutting down.....	8
Installation and setting up	9
Location.....	9
AC power.....	9
Setting up	9
Final checks	10
Turning on the power.....	10
Shutting down after use.....	10
Control settings	11
Overview	11
Fast access buttons.....	11
Setting haze density	11
Setting fan speed	12
Auto fan mode	12
Setting Run mode.....	12
Setting the Timer	12
Setting the DMX base address.....	12
Setting the master-slave link mode.....	13
Aux option	13
Priming the machine after fluid out	13
Resetting options to factory settings.....	14
Remote control.....	15
Overview	15
Functions.....	15
DMX control	16
Overview	16
Connection	16
DMX functions	16
Fog fluid type	17
Basic service.....	18
Cleaning	18
Fuse replacement.....	18
Troubleshooting	19
Status messages	20
Specifications.....	21
Notes	23

Safety information

READ AND SAVE THESE INSTRUCTIONS

The following symbols are used to identify important safety information:



Caution! Safety hazard. Risk of personal injury.



Caution! Burn hazard. Hot surface. Do not touch.



Danger! Hazardous voltage. Contact will cause electric shock.



Caution! Fire hazard.



Warning! This product is not for household use. It presents risks of injury due to electric shock, burns, falls and respiratory problems!

Before operating the machine – **Read and retain these Instructions**
Avant l'opération – **Lire et conserver ces instructions**

Read this manual before operating the machine, follow the safety precautions listed below, and observe all warnings in this manual and printed on the machine. Use the system only as described in this manual and in accordance with local laws and regulations.

If you have questions about how to operate the machine safely, or if you have followed the instructions in this manual and the machine is malfunctioning, please contact Martin Service.

Preventing electric shocks



- Always ground (earth) the machine electrically.
- Use only a source of AC power that complies with local building and electrical codes, and that has both overload-and ground-fault protection.
- Before connecting the JEM K1 Hazer to power, check that the voltage indicated on the machine's serial label matches your local AC power voltage. If your AC power voltage does not match, do not use the machine. Contact Martin Service for assistance.
- Before using the machine, check that all power distribution equipment and cables are in perfect condition and rated for the current requirements of all connected devices.
- If the machine or any cables connected to it are in any way damaged, defective, wet, or show signs of overheating, stop using the machine and contact Martin Service for assistance. If the supply cord is damaged, it must be replaced by a special cord or assembly available from the manufacturer or its service agent.
- Disconnect the machine from AC power before servicing and when not in use.

- This system is not waterproof and should not be exposed to wet outdoor conditions. Do not immerse in water or any other liquid. Do not expose to high-pressure water jets.
- Do not spill fluid over or inside the machine. If fluid is spilled, disconnect AC power and clean with a damp cloth. If fluid is spilled onto electronic parts, take the system out of service and contact Martin for advice.
- Do not remove the covers or attempt to repair a faulty machine. Refer any service not described in this manual to Martin.
- Do not operate the machine if any parts are damaged, defective or missing.
- Moisture and electricity do not mix. Do not aim the haze output at electrical connections or devices.

Preventing burns and fire



- The haze produced by the machine is hot enough to cause burns when it leaves the nozzle, and very hot droplets of fluid escape occasionally. Keep people and objects at least 1 meter (39 inches) away from the haze output nozzle.
- Do not touch the haze output nozzle during or after use – it becomes extremely hot and remains hot for several hours after the machine has been shut down.
- Haze output contains glycol, a flammable alcohol that burns with an almost invisible blue flame. Do not point the haze output at sources of ignition such as open flames or pyrotechnic effects.
- Do not attempt to bypass thermostatic switches, fluid sensors or fuses.
- Replace fuses only with ones of the type and rating specified in this manual for the machine.
- Provide a minimum free space of 100mm (4 inches) around the machine.
- Provide a minimum free space of 500mm (20 inches) around fans and air vents and ensure free and unobstructed air flow to and around the machine.
- Keep the machine at least 600mm (24 inches) away from combustible and heat-sensitive materials.
- Do not operate the machine if the ambient temperature (Ta) is below 5° C (41° F) or above 40° C (104° F).
- Do not operate the machine if the relative air humidity exceeds 80%.

Preventing injuries



- Ensure that the surface on which the machine is located or installed can safely hold the weight of the machine.
- Do not install the machine over areas where people are present.
- This appliance is not intended for use by persons (including children) with reduced physical sensory or mental capabilities, or lack of experience and knowledge, unless they have been given supervision or instruction concerning use of the appliance by a person responsible for their safety. Children should be supervised to ensure that they do not play with the appliance.
- Haze machines can cause condensation. Do not point the output at smooth floors. Floors and surfaces may become slippery. Check these frequently and wipe dry as necessary to avoid any danger of slipping.
- Ensure at least 2m visibility in areas where haze is being produced.

- Haze fluid contains food-grade glycols in solution but may present health risks if swallowed. Do not drink it. Store it securely. If eye contact occurs, rinse with water. If fluid is swallowed, give water and obtain medical advice.

Preventing breathing problems



- A haze machine can operate safely only with the haze fluid it is designed for. Use the machine only with the fluid specified under “Haze fluid options” on page 17 or you may cause the release of toxic gases, presenting a severe health hazard. You will also probably damage the machine.
- Do not create dense haze in confined or poorly ventilated areas.
- Do not expose people with health problems (including allergic and/or respiratory conditions such as asthma) to haze output.
- Do not point the haze output directly at a person’s face or at face height.

General warnings



- Read instructions before use - *Lisez les instructions avant l’emploi.*
- Keep output 60 cm away from people and surfaces - *Maintenir la buse à 60 cm des personnes et des surfaces.*
- Avoid installing over people’s heads - *Evitez d’installer au dessus des personnes.*
- Use only Martin K1 Haze fluid - *Utilisez que du fluide Martin K1.*
- Prolonged use may cause condensation to form; check floors and surfaces regularly - *Une utilisation prolongée peut causer la formation de condensation; vérifiez les sols et les surfaces régulièrement.*
- May affect sufferers of severe respiratory disorders - *Peut affecter les victimes souffrantes de troubles respiratoires sévères.*
- Disconnect supply before opening case; refer servicing to qualified personal - *coupez l’alimentation avant d’ouvrir la machine; confiez l’entretien à un personnel qualifié.*
- Not for domestic use - *Pas fait pour une utilisation domestique*
- Surfaces may become very hot during use - *Les surfaces peuvent devenir très chaudes pendant l’ utilisation.*

Product overview

Product description

The JEM K1 Hazer™ from Martin is a top of the range solution to a wide variety of atmospheric requirements whether permanently installed or taken on the road.

Featuring a revolutionary new block design and a high volume radial blower, the JEM K1 Hazer™ can quickly produce large volumes of haze to create large scale effects in the biggest venues.

Congratulations on your purchase of the JEM K1 Hazer™ from Martin. Details of the full range of Martin products are available on our website at www.martin.com.

Features at a glance

- Attractive and rugged design
- High speed radial blower
- Revolutionary block design for high output and reliability
- Control panel with alphanumeric display
- Optional full function digital remote with display (25m max cable length)
- Carrying handles
- DMX control (2 channels)
- Standby battery runs shutdown procedure after power down

Product details

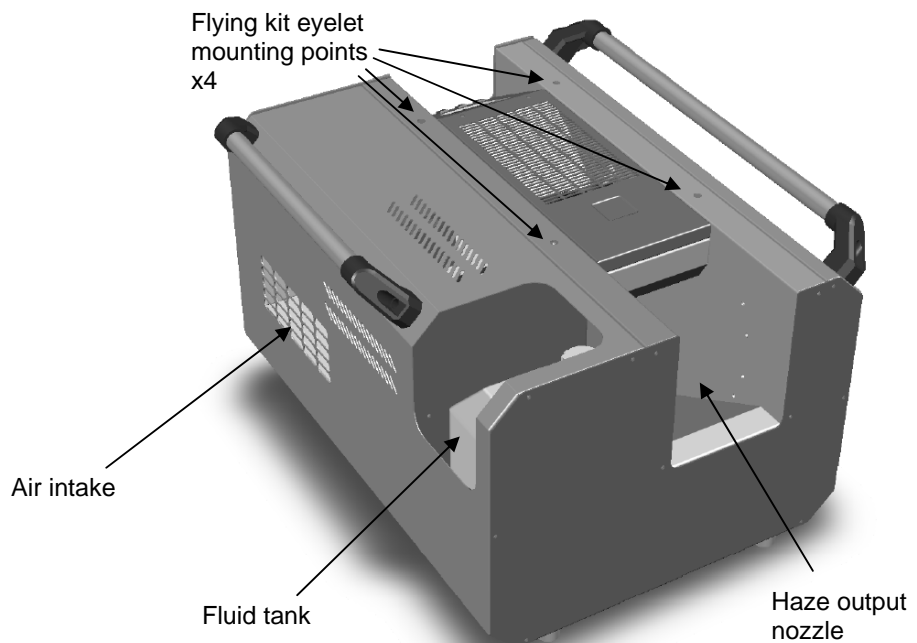
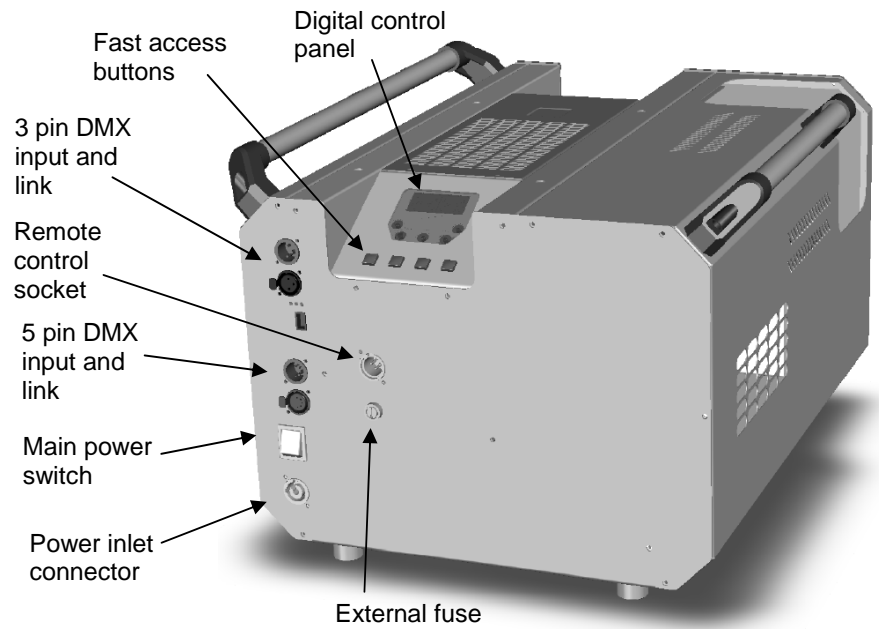

Warning, high temperature vapour and surfaces!

Quick Start

You are no doubt eager to switch on the machine and try it out by making a lot of haze. This section tells you how to do that. However, please also make the time to read the safety and servicing instructions in the remainder of this manual.

Setting up

Locate the machine in a suitably large area with nothing in front of the haze output.

Fill the fluid tank with MARTIN-approved haze fluid (see page 17).

Connect a suitably rated power supply to the machine. The power requirements are:

6.3A at 230V (EU) or 10A at 120V (US)

If you are using the optional remote control, connect it to the REMOTE IN connector on the rear panel.

Turn on the main power switch located next to the power cable inlet.

Making haze

Press either ECO / PRE1 / PRE2 from the Fast Access Mode on the onboard control panel. If using the optional remote control, press the HAZE button. The display will show H E A T for about 5-7 minutes, once heated the machine will start to produce haze at the selected level. If the machine is new or has run out of fluid, page 13 'Priming the machine' should be referenced.

Shutting down

When you turn off the power, the unit will switch to its backup battery and enter a 3 minute shutdown procedure. This clears the block of any residual fluid to prevent clogging. During shutdown the display shows "WT" with a countdown.

Installation and setting up



DANGER! DO NOT operate the JEM K1 Hazer™ until you have read and observed all the precautions listed under “Safety information” on page 3.

Location

The JEM K1 Hazer™ should be located on a solid surface such as the floor.

The machine can operate in any orientation from 45 degrees upwards to 45 degrees downwards. Steeper tilting may cause fluid leakage.

Do not suspend the machine over areas where people will be underneath.

Ensure that there is at least 100mm clearance all round the machine and at least 600mm in front of the haze output.

AC power

Before using the machine, ensure that a grounding-type (earthed) power plug that fits the local power outlets is installed on the power cable.



DANGER! Make sure the power plug is correctly rated:

- EU (230V) fit a plug rated 6 amp minimum
- US (120V) fit a plug rated 10 amp minimum

When installing the plug, follow the plug manufacturer’s instructions and connect pins as follows:

yellow and green wire to ground (earth), blue wire to neutral and brown wire to live.

The table below shows some common pin identification schemes.

wire	function	marking	screw colour
brown	live	“L”	yellow or brass
blue	neutral	“N”	silver
green/yellow	earth		green

Before connecting the JEM K1 Hazer™ to power, verify that the AC supply is adequately dimensioned for the current draw of the machine. The machine requires:

6.3A at 230V (EU) or 10A at 120V (US)

Check that the local AC voltage is appropriate, as indicated on the machine’s serial number label. If your AC voltage is outside the appropriate range, do not use the machine. Contact Martin Service for assistance.

Setting up

Fill the fluid tank with Martin approved fluid (see page 17).

If DMX control is being used, connect the machine to the DMX line (see page 16).

If the JEM K1™ Digital Remote is being used (optional accessory), connect the remote to the Remote socket. (see page 16)

Final checks

Before applying power to the JEM K1 Hazer™, verify the following:

- the machine is safely located or installed and meets the location requirements stated on page 9
- the operator is familiar with, and able to comply with, the requirements for safe operation listed on page 3
- the haze fluid is genuine Martin fluid listed under “Haze fluid options” on page 17
- the machine is electrically grounded (earthed)
- the AC power distribution circuits and lines are adequately rated for the current load

Turning on the power

Turn on the main power switch located next to the power cable inlet and select **S T B Y #** (Standby) from the **Q U N** menu.

The display will show **H E A T** for about 5-7 minutes as the machine heats up to operating temperature and will then change to **Q D Y** (Ready).

You can then use the remote control, control panel or dmx signal to start haze production.

Shutting down after use

When you turn off the power, the unit will switch to its backup battery and enter a 3 minute shutdown procedure. This clears the block of any residual fluid to prevent clogging. During shutdown the display shows “WT” with a countdown.

You can also shut down the machine by setting the **Q U N** menu to **O F F**. The 3 minute shutdown procedure will be activated. This can be done from the digital remote or from the onboard control panel. The heater, fan and pump will be shut down but the machine will remain powered and can be reactivated by either following the steps above in ‘Turning on the power’ or following the ‘Quick Start’ guide.

Control settings

Overview

By selecting either ECO / PRE1/ PRE2 from the **Fast Access** buttons below the digital display at the rear of the unit allow you to quickly turn the haze on or off at three different settings.

The **digital display** allows you to configure all options of the machine using menu, if you need more detailed control.

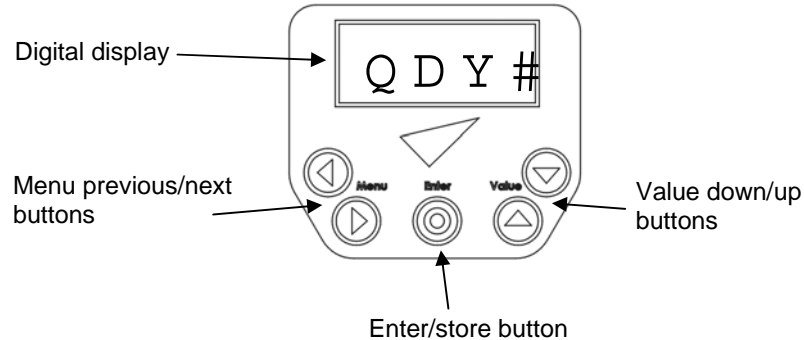

Fast Access buttons

The four Fast Access buttons allow you to quickly set the machine to one of three haze output levels and a Silent mode (SLNT). The display shows the current setting.

If you press the same button again, haze output will stop and the machine will go back to Ready mode. (SLNT) mode returns to previous state.

Fast Access Mode	Haze and Fan settings	DMX Value Equivalent	
		CH1	CH2
SLNT #	Drops Fan levels by 30% relative to current values#	-	Reduce by 30% of current value
ECO #	Haze 5%, Fan 5%#	30	11
RQE2 #	Haze 50%, Fan 50%	120	110
RQE3 #	Haze 100%, Fan 100%	219	219

Setting haze density

Use the Menu Previous / Next buttons to select the HAZE option.

Use the Up/Down buttons to select the density from 1 (- 2 1 1 (.

Press the Enter button to store the haze setting. The display shows SET .

The machine will only produce haze if the RUN menu is set to TIME or CONT. (Or, if using the digital remote, if you press the Timer or Haze buttons).



If you want to temporarily change the haze density, do not press Enter. The haze setting will go back to its stored value next time the machine is powered up. This applies to all options.

Setting Fan speed

Use the Previous / Next buttons to select the **FAN** option.
Use the Up/Down buttons to select the fan speed from 1 (- 2 1 1 (.
Press the Enter button to store the fan setting.

The fan will run continuously if set above 0% and the **QUN** menu is set to **FAN**, **TIME** or **CONT**.

If haze is being produced and the fan is off or set to a low speed, the fan speed will be automatically increased to prevent build-up of haze at the machine output.

Auto Fan Mode

In some circumstances where an improved vertical distribution of haze is required, **AUTO #** can be selected from the **FAN #** menu. This causes the fan speed to vary over a 5 minute period.

Setting Run mode

Use the Previous / Next buttons to select the **QUN** option.
Use the Up/Down buttons to select the operating mode.
OFF : heater off, fan off. Used when the machine is to be shut down.#
STBY : heater on, fan off. The machine is ready but not hazing
FAN # # Fan on. Machine ready but not hazing.
TIME : enable timed pulses of haze.#
CONT : enable continuous haze.
Press the Enter button to store the Run setting.
When the mode is changed to **OFF**, the unit will enter a 3 minute shut down sequence before powering down, to prevent block clogging. The display shows **WAIT** then **WT** with a countdown. You can cancel the shut down sequence by changing the run mode back to an active state.

Setting the Timer

If smaller amounts of haze are required the machine has an automatic timer to give timed bursts of haze. You can set the "Run" and "Off" times independently between 1 and 90 seconds.

Use the Previous / Next buttons to select the **TQUN** or **TOFF** option.
Use the Up/Down buttons to select the run or off time from 2 seconds to : 1 seconds. If you hold down the button the time will count up or down, getting faster the longer you hold it.
Press the Enter button to store the timer setting.

To enable timer mode, select **TIME** from the **RUN** menu (or, if using the digital remote, press the Timer button).



*When the timer is running and the display is not showing a menu, the display shows a countdown for the run time **TQUN** and the off time **TOFF**.*

Setting the DMX base address

Use the Previous / Next buttons to select the **ADDQ** option.

Use the Up/Down buttons to set the DMX base address from 1 1 2 to 6 2 1 . If you hold down the button the address will count up or down, getting faster the longer you hold it.

Press the Enter button to store the address setting.

The machine will automatically respond to a DMX controller whenever it is connected.

Setting the master-slave link mode

It is possible to control several machines from one digital remote. The machine with the remote plugged into it becomes the Master. The other machines are Slaves. The machines are interconnected with DMX cabling.

Use the Previous / Next buttons to select the L I N K option.

Use the Up/Down buttons to select Q E C V or S E N D .

Press the Enter button to store the link setting.

The machine should be set to S E N D only if it is running as a master. If running as a slave, stand-alone or DMX controlled it should be set to Q E C V .

Aux option

This option is not currently used and has no effect on the machine.

Priming the machine

If the machine runs out of fluid or you are priming a new machine, use the PRIME function:

Use the Previous / Next buttons to select the R Q M E option.

Use the Up/Down buttons to change the option to Y .

Press the Enter button to start the priming function.

The machine will pump until it detects fluid entering the block

To exit this menu if you decide not to activate the Prime function, select N and press Enter.

If the machine is not up to operating temperature the Prime function will do nothing.

Resetting options to factory settings

The factory settings configure a standard mode of operation for the machine.

Use the Previous / Next buttons to select the `Q S E T` option.

Use the Up/Down buttons to change the option to `Y`.

Press the Enter button to reset all options.

To exit this menu if you decide not to reset the options, select `N` and press Enter.

The factory settings are:

option	setting
HAZE#	6 1 (#
FAN#	6 1 (#
TRUN#	2 1 #
TOFF#	3 1 #
RUN	S T B Y #
LINK	Q E C V #

Remote control

Overview

The JEM K1™ Digital Remote control, available separately, may be used for remote control of the JEM K1 Hazer™. Several machines may be controlled from one remote using the LINK function (see page 13).

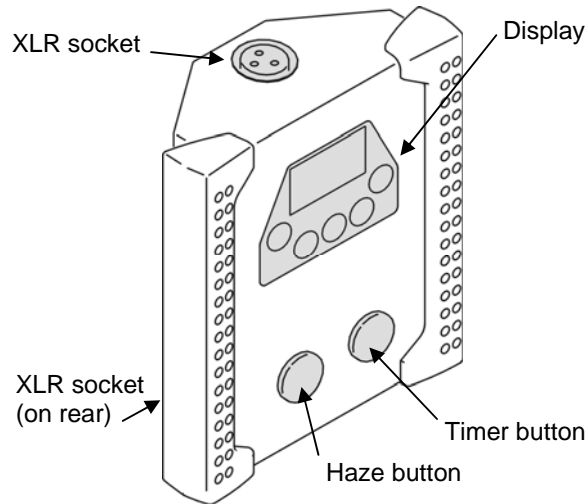

Functions

The remote control provides the following functions:

- Haze button: turns haze output on and off. Press once to start haze and again to stop.
- Timer button: turns the haze timer on and off.
- Haze level setting (HAZE = 0 -100%)
- Fan speed setting (FAN = 0 -100%)
- Timer run time/off time settings (T Q U N , T O F F = 0 - 90 seconds)
- Run mode (RUN = O F F , S T B Y , F A N , T I M E , C O N T)

The functions are the same as on the built in control panel and are described on page 11.

The Haze button works by setting RUN to C O N T (or S T B Y). The Timer button sets RUN to T I M E or S T B Y . These buttons are simply a quick way to control this menu function.

DMX control

Overview

DMX is a digital control system widely used in entertainment and architectural lighting. Any controller meeting the DMX-512 standard may be used to control and program the haze output of the JEM K1 Hazer™.



When a DMX signal is present, the JEM K1 Hazer™ stand-alone functions do not work. To fire the unit from the control panel or remote control, the DMX controller must be powered off or disconnected.

Connection

The JEM K1 Hazer™ provides both 3-pin and 5-pin XLR sockets on the rear panel of the machine for DMX connection. The sockets are interconnected: a DMX line connected to the 3-pin IN socket may be continued through the 5-pin OUT socket and vice versa. Do not, however, attempt to split a DMX line by using both the 3-pin and 5-pin OUT sockets.

For best results, use cable designed for high speed digital data transmission. Suitable DMX cable is available from your Martin dealer.

DMX functions

The JEM K1 Hazer™ address setting must match the DMX address allocated to it on the controller. To set the address, see “Setting the DMX base address” on page 12. The JEM K1 Hazer™ requires two DMX channels.

DMX channel 1	Function: Haze Density
0-19#	Standby#
20-219#	Proportional output level control
220-255	Prime

DMX channel 2	Function: Fan Speed
0-219	0-100%, heaters on
220-244	Auto fan mode
245-255	Machine shutdown, heaters off

For example if the JEM K1 Hazer™ is set to DMX address 100, channel 1 will be controlled by address 100 and channel 2 will be controlled by address 101.

When the machine is at running temperature and is under DMX control it displays `DMX`.

Fog fluid types

The following type of Martin fog fluid is suitable for use in this machine. Martin supplies high quality fog fluids that are based on ultra-pure deionised water. Use only the following genuine Martin fog fluid. No other fluid is suitable for use.



DANGER! The JEM K1 Hazer™ can run safely only on the specific haze fluid it is designed for. Use **ONLY** the Martin haze fluid designated in this manual. **NEVER** use any other type of fluid, or toxic gas may be produced. You will probably also cause damage to the system that is not covered by the product warranty. Do not dilute haze fluid with water or any other liquid. Discard haze fluid if it becomes contaminated.

JEM K1™ Haze Fluid

JEM K1™ fluid is a light molecular fluid which generates an invisible canvas, specially designed to project light beams and lasers. The haze is slow dispersing with an extended, long hang time.

Basic service



Before servicing the JEM K1 Hazer™, read and observe all the precautions listed in “Safety information” on page 3. Any service not described in this section must be carried out by a Martin service technician.

Cleaning

Excessive dust, haze fluid, and dirt build-up will degrade performance and cause overheating and damage to the machine that is not covered by the product warranty. To maintain adequate cooling, dust must be cleaned from the outer casing and air vents of the machine periodically.



Isolate the machine from power and allow to cool completely before cleaning. The haze output nozzle remains hot for up to 10 hours after use.

- Remove dust from the air vents with a soft brush, cotton swab, vacuum, or compressed air.
- Clean haze fluid residues from the output of the machine.
- Clean the outer casing with a damp cloth only.

Error messages

If the display shows \boxtimes \square \square , the machine has detected an internal fault. Switch off the machine and contact Martin Service.

Fuse replacement

The main fuse for the JEM K1 Hazer™ is in a fuse holder located adjacent to the power inlet. To replace the fuse, disconnect the power cord from the supply, unscrew the cap of the fuse holder and pull out the fuse. Remove the spent fuse and replace with one of exactly the same size and rating. The fuse type is indicated on the serial number label as well as below. Contact Martin Service if the fuse blows repeatedly.

Troubleshooting

Problem	Probable cause(s)	Suggested remedy
Machine will not produce haze when control panel or remote control HAZE switch turned on#	Machine not at operating temperature	Wait 5 to 7 minutes#
	H A Z E set to 0#	Increase setting#
	T Q U N set to 0	Increase setting
	DMX signal present	Disconnect or turn off DMX controller
Machine can be fired from control panel or remote control, but not by DMX controller	DMX address setting incorrect	Change DMX address (page 12)
	Poor connection in DMX line	Check DMX cables and connections
Haze output is weak	Machine requires priming	Prime machine (page 13)
Wet, greasy, non-uniform haze output, fluid drips or spits from nozzle, or very loud noise when firing machine	Incompatible haze fluid	Use approved fluid!
Machine appears dead	Mains fuse blown	Replace fuse (page 18)
	No power at AC cable inlet	Check power cable and circuit breaker

Status messages

message	reason
OFF #	The heaters are Off, the unit is shut down.
HEAT #	The unit is heating up to operating temperature.
QDY #	The heater is at operating temperature, but Haze is not turned on.
DMX #	The heater is at operating temperature and the unit is under DMX control.
TQUN # 2 1 #	(Number may be 01 to 90): Machine is in timer mode, counting down the run period.
TOFF # 2 1 #	(Number may be 01 to 90): Machine is in timer mode, counting down the off period.
WT 3 1 #	(Number may be 90 to 00): The machine is carrying out its shutdown sequence.
CAL #EQQ #	The machine has detected an error with its calibration settings and will not operate. Call Martin Service.
AIQ #EQQ #	The air pump is not working. This indicates a fault. Turn the machine off and call Martin Service.
FLU #EQQ #	The fluid pump is not working. This indicates a fault. Turn the machine off and call Martin Service.
HEAT #EQQ #	The heater is at too high a temperature. This indicates a fault. Turn the machine off and call Martin Service.
SEQV #	(on start-up) The machine's run time has passed its recommended service interval. The machine is safe to use but should be serviced as soon as is convenient.
BATT #	(on start-up) The internal battery is low and the last shutdown did not complete. If this message displays on every start-up, call Martin Service to obtain a replacement battery.

Specifications

Physical

Length.....	544mm
Width	459mm
Height	344mm
Dry weight.....	21.5Kg

Performance

Effect coverage	5000m ³ /min
Operating time	continuous
Warm up time	5 minutes
Safety device	DTP device

Control and programming

Control options	DMX, digital remote
DMX channels	2

Fluid system

Capacity.....	2.5 litre
Fluid consumption (max)	140ml/hr
Compatible fluids	K1 Haze

Connections

DMX.....	3 or 5 pin XLR
Remote / machine link	3 pin XLR
AC power	PowerCon

Electrical

AC voltage	120V / 230V, 50/60Hz
Main fuse (120V US version)	10AT
Main fuse (230V EU version)	5AT
Power usage (120V US version)	675W (6.0A)
Power usage (230V EU version)	675W (3.1A)

Thermal

Maximum ambient temperature (Ta max)	40°C (104°F)
Exterior surface temperature, steady state, at 20°C ambient	40°C (104°F)

Approvals

European EMC:	EN 61000-6-3:2001 – Part 6-3
European safety:.....	EN 60 335-1:2002
Immunity:	EN 61000-6-1:2001 – Part6-1
ETL approval (cETLus).....	UL Std.998, CAN/CSA Std. C22.2 No 104-01

Included items:

EU Model:

2.5m (6.56ft) power cable 3x1.0mm² with PowerCoN™ male connector

US Model:

2m (6.5ft) US power cable 18AWG with Nema 5-15 plug to PowerCoN™ male connector (UL approved)

1 x 2.5L fluid container (empty)

Ordering information

Martin JEM K1 Hazer™ 120V	92225900
Martin JEM K1 Hazer™ 230V	92225901
JEM K1™ digital remote control.....	92765036
Flying Kit for Martin JEM K1 Hazer™.....	92610002
Flightcase for Martin JEM K1 Hazer™	91540012

Notes



Martin Professional A/S, Olof Palmes Allé 18, DK-8200, Aarhus N
Phone: +45 87 40 00 00 Internet: www.martin.com